

# Service Schematics



## Introduction

### **Important:**

**This document is intended for use by authorized service centers only.**

“Service Schematics” was created with focus on customer care.  
The purpose of this document is to provide further technical repair information for NOKIA mobile phones on Level 3/4 service activities.  
It contains additional information such as e.g. “Component finder”,

Saving process time and improving the repair quality is the aim of this document.  
It is to be used additionally to the service manual and other training or service information such as Service Bulletins.

While every endeavour has been made to ensure the accuracy of this document, some errors may exist. If the reader finds any errors, NOKIA should be notified in writing.

Please send E-Mail to: [TrainingAndVendor.Development@nokia.com](mailto:TrainingAndVendor.Development@nokia.com)

## RM-249 / RM-250



### Table of contents

Frontpage	1
AV connector	2
AVILMA & BETTY	3
RAPGSM & Combo memory	4
User interface	5
Bluetooth & FM radio	6
Camera	7
RF part	8
Component finder	9

Copyright © NOKIA

This material, including documentation and any related computer programs is protected by copyright, controlled by NOKIA. All rights are reserved. Copying, including reproducing, modifying, storing, adapting or translating any or all of this material requires the prior written consent of NOKIA. This material also contains confidential information, which may not be disclosed to others without the prior written consent of NOKIA.

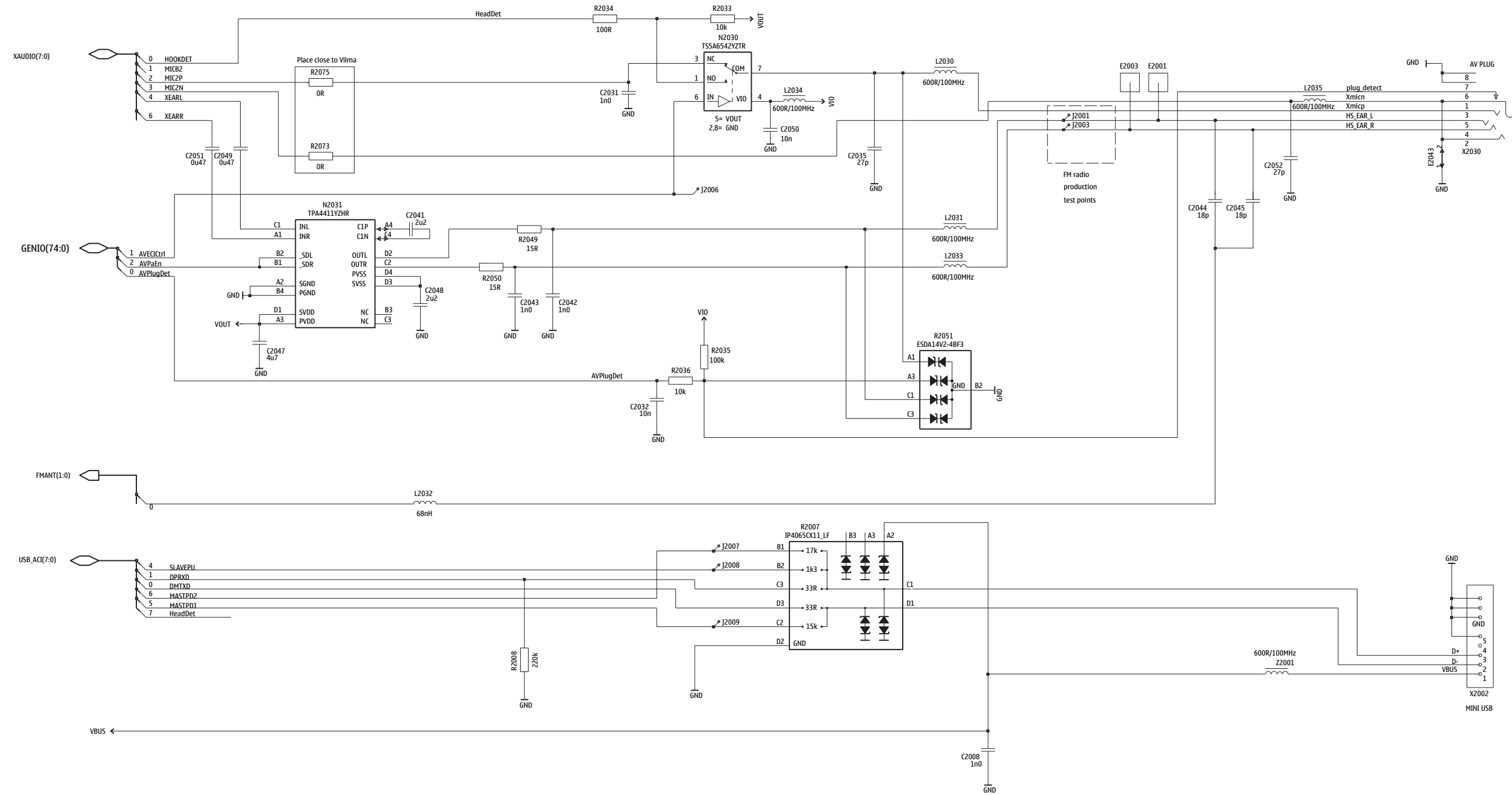

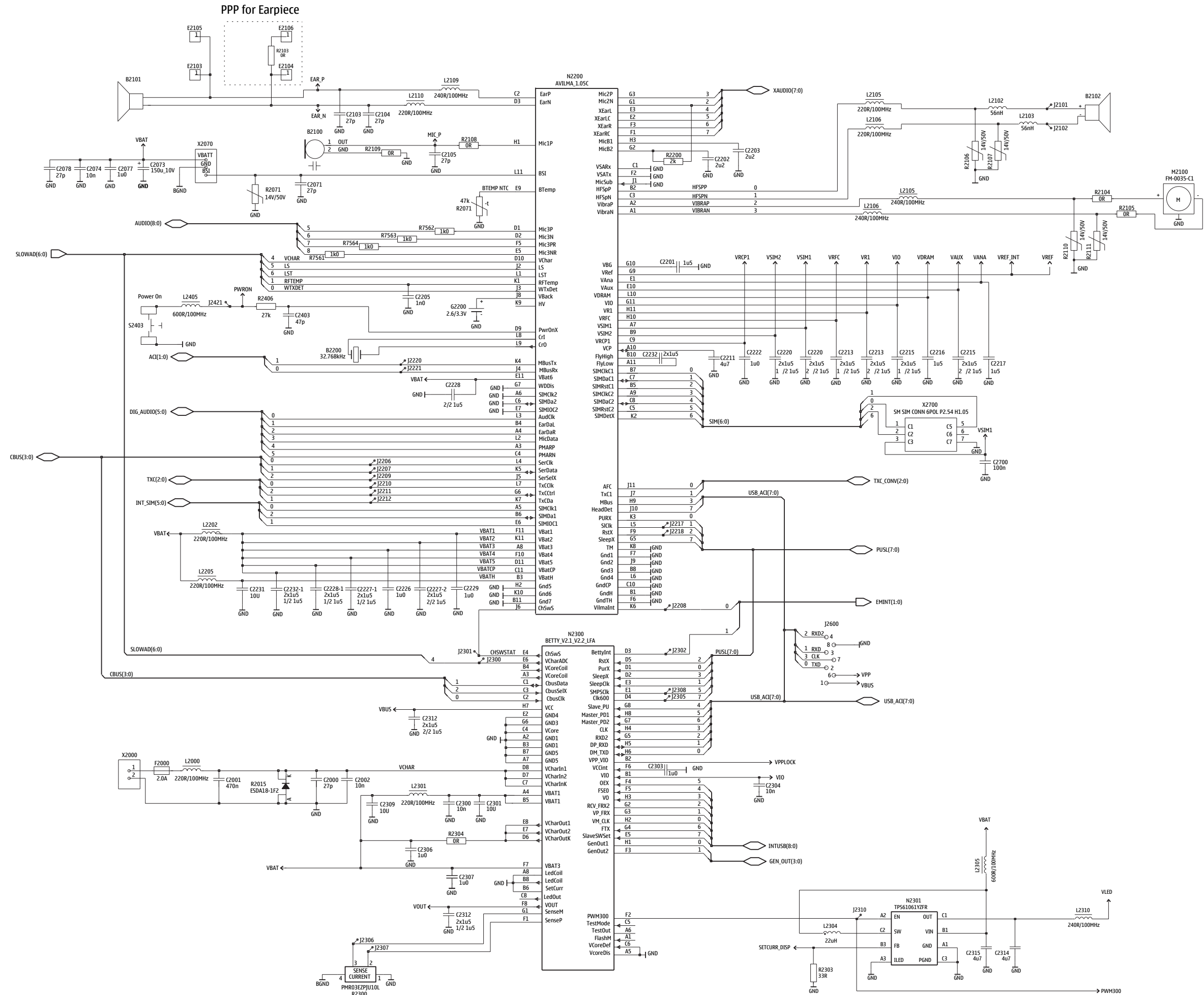

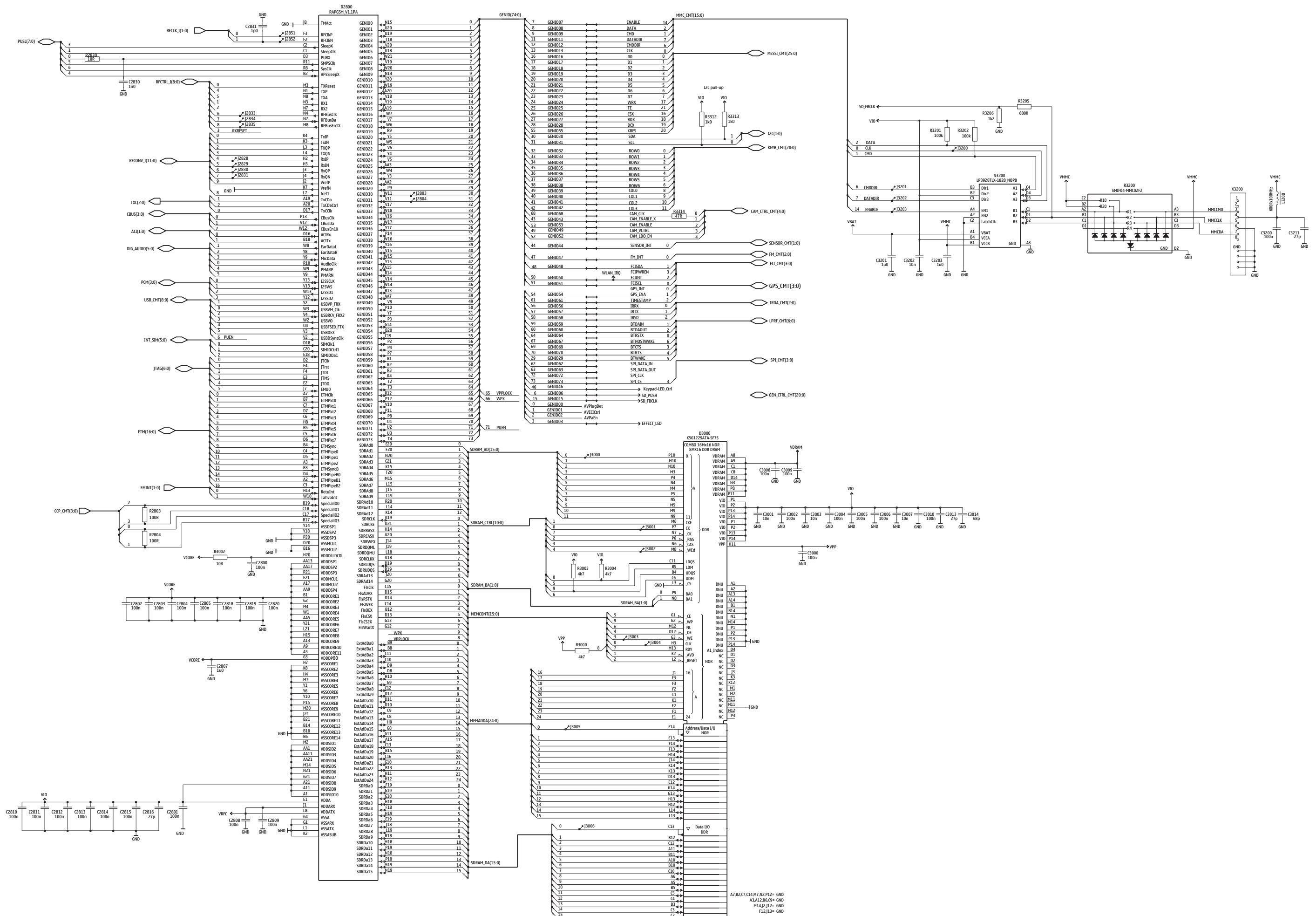

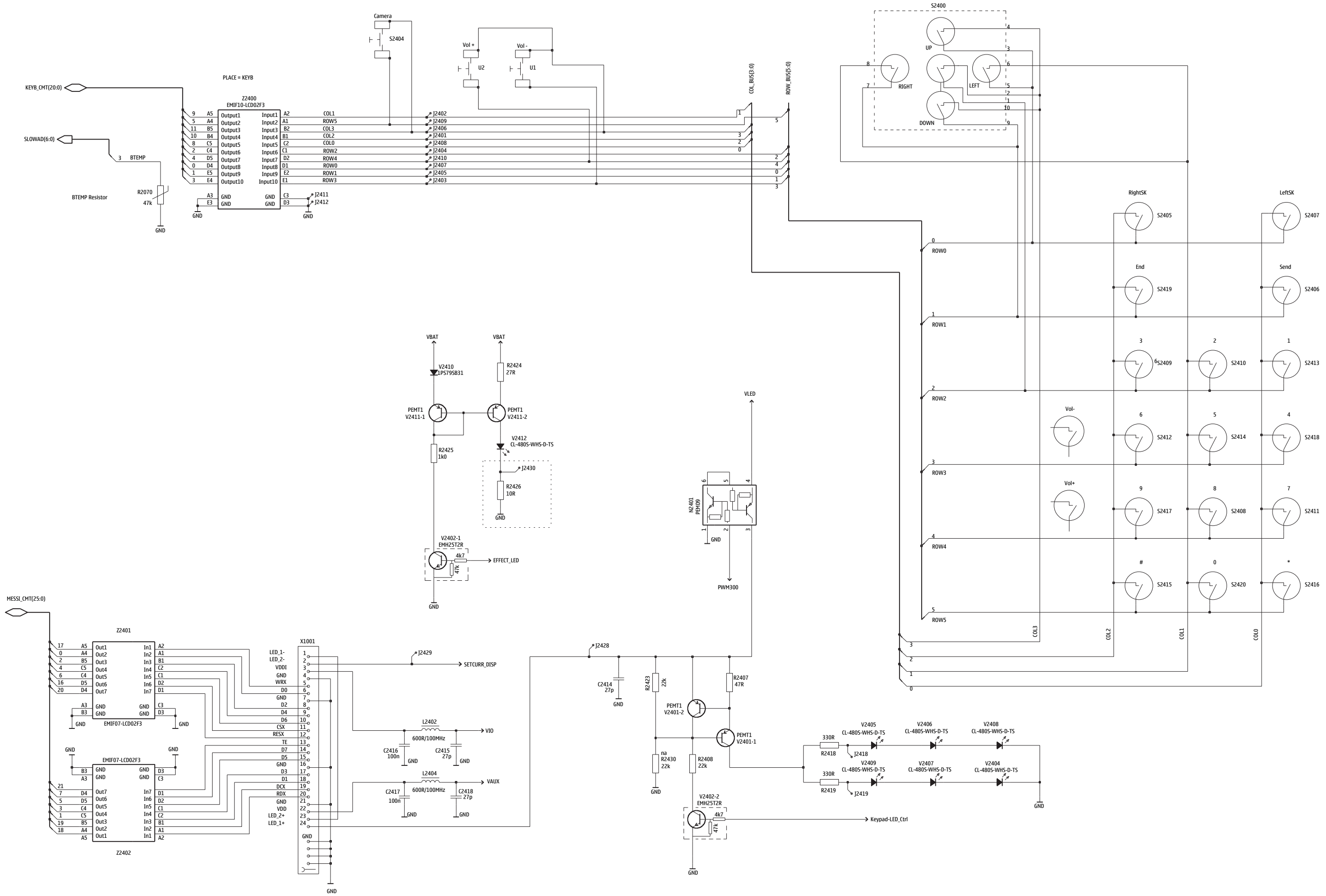

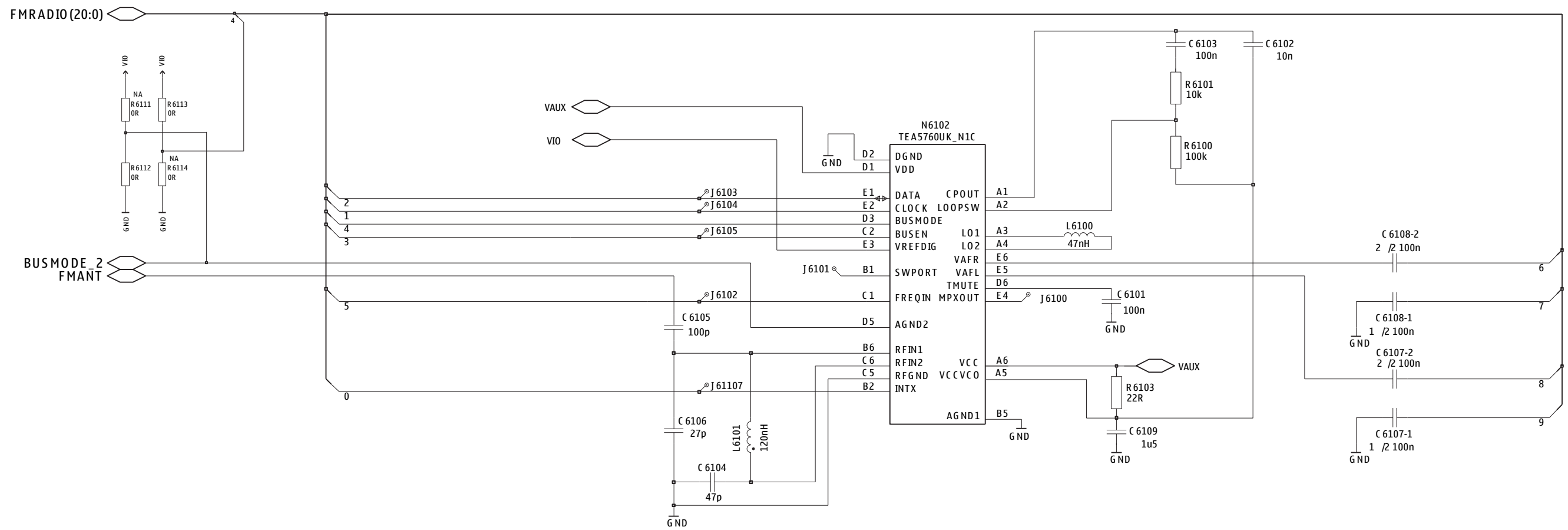
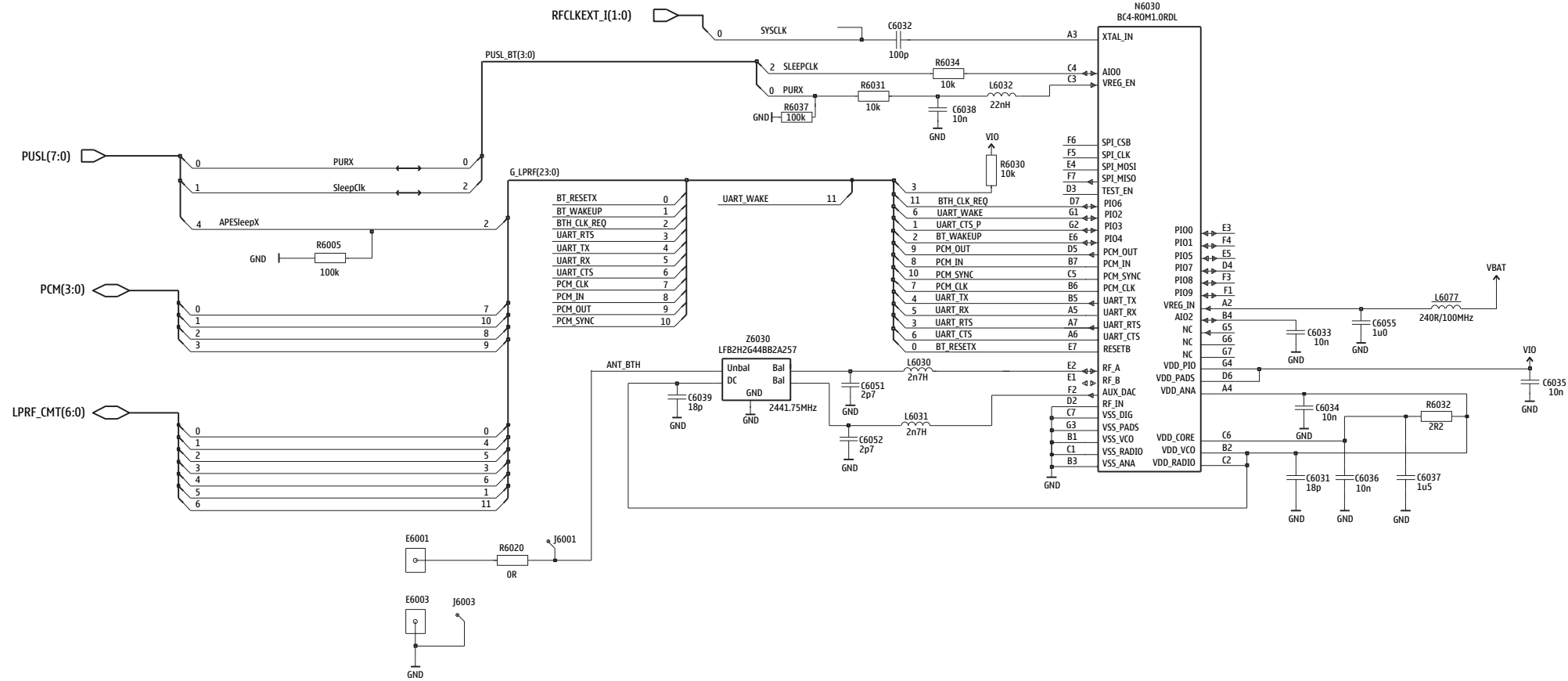

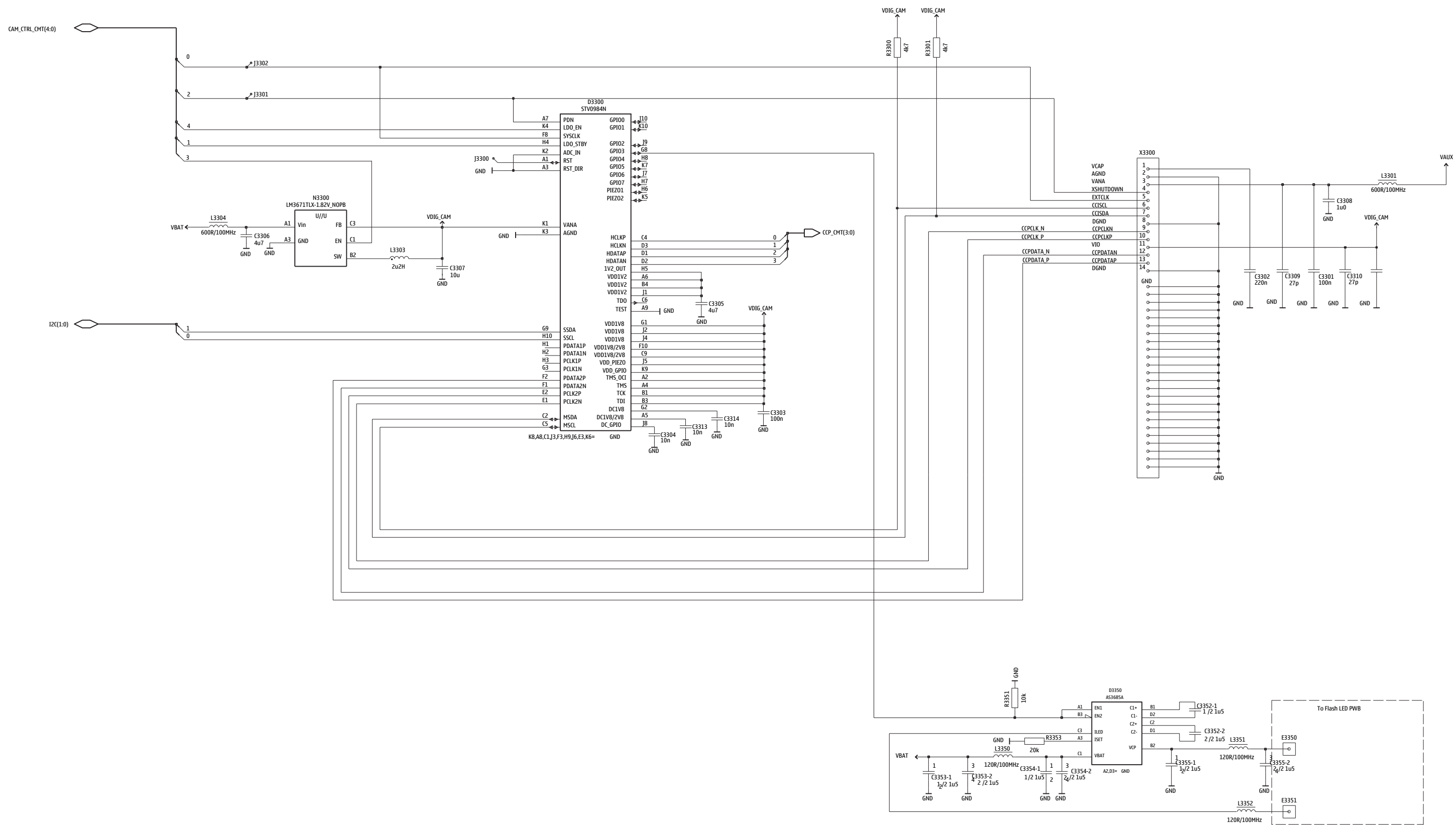



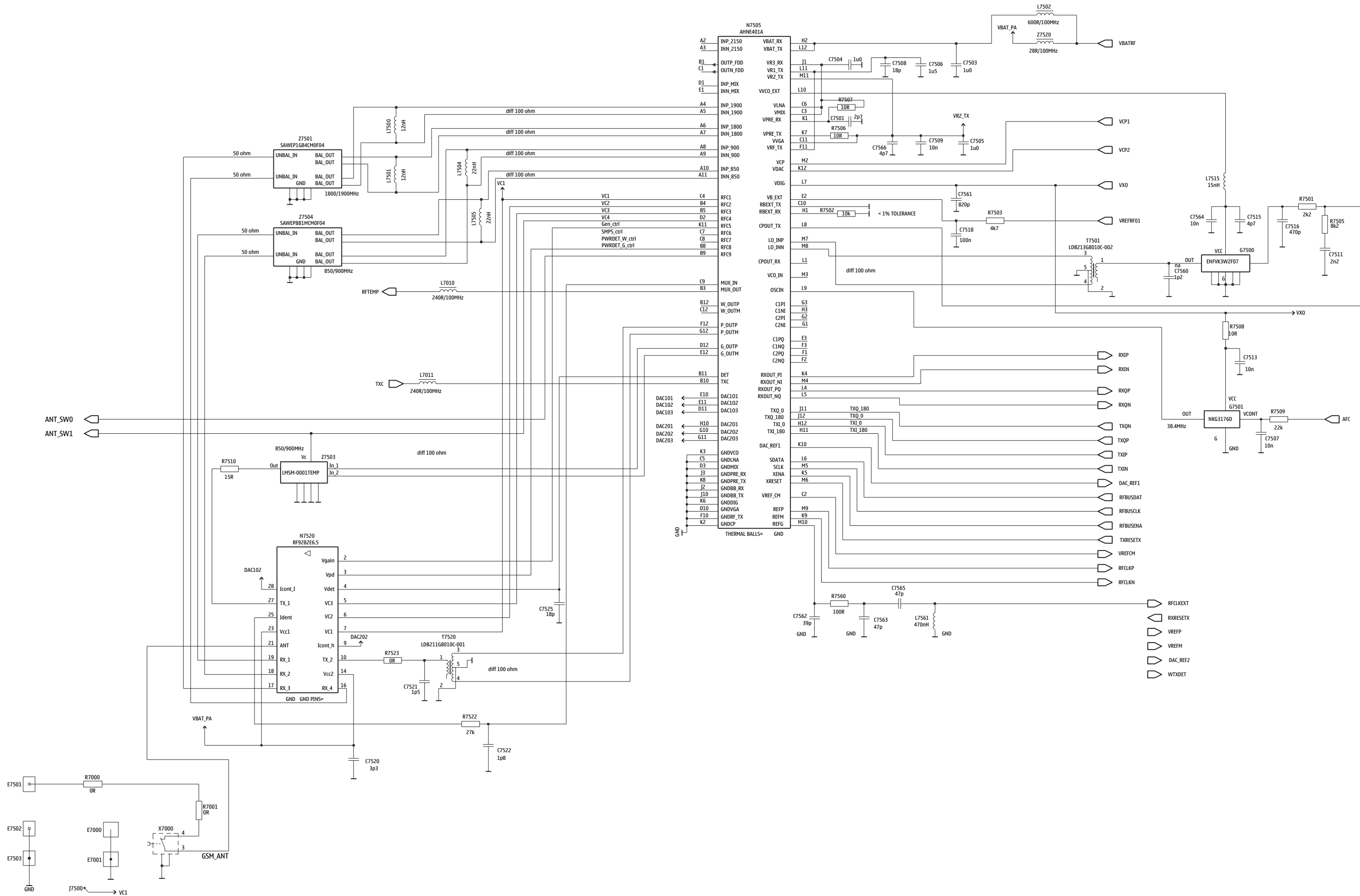



B	C2802	M8	C6102	E6	F	R	R6107	E7			
B2100	B7	C2803	L8	C6103	E6	F2000	A6	R2007	D3	R6108	E5
B2101	U6	C2804	N8	C6104	D6	G		R2008	D2	R6109	D7
B2200	K2	C2805	K5	C6105	D7	G2200	D2	R2033	E4	R6111	F8
C	C2807	N8	C6106	D6	G7500	T3	R2034	E4	R6112	F8	
C2000	A3	C2808	M8	C6107	E5	G7501	R3	R2035	D5	R6113	F7
C2001	A5	C2809	M8	C6108	D5	L		R2036	D5	R6114	E7
C2002	C3	C2810	L8	C6109	D7	L2000	B5	R2049	D4	R7000	U8
C2008	D2	C2811	K6	C6110	E6	L2030	D4	R2050	D4	R7001	U8
C2030	E4	C2812	M8	C7000	U8	L2031	D4	R2051	D5	R7501	S4
C2031	E5	C2813	N5	C7001	U8	L2032	E5	R2052	D4	R7502	T5
C2032	D5	C2814	M8	C7010	Q5	L2033	E5	R2070	F2	R7503	R5
C2035	D5	C2815	K8	C7011	Q4	L2034	E5	R2071	I4	R7505	S4
C2041	C3	C2816	K8	C7012	Q5	L2035	D4	R2073	F4	R7506	R4
C2042	D4	C2818	K6	C7013	Q4	L2102	Q7	R2075	F4	R7507	T5
C2043	D4	C2819	K7	C7501	T5	L2103	Q8	R2102	Q4	R7508	R4
C2044	D4	C2820	N6	C7502	R5	L2105	Q5	R2103	Q4	R7509	R4
C2045	D5	C2821	N6	C7503	R4	L2106	Q5	R2104	A7	R7510	R8
C2046	D4	C2830	N7	C7504	T5	L2107	A6	R2105	B7	R7522	R8
C2047	D4	C2831	N7	C7505	R4	L2108	B6	R2106	Q5	R7523	T8
C2048	C3	C3000	I5	C7506	R4	L2109	P1	R2107	Q5	R7560	R5
C2049	I5	C3001	J5	C7507	R4	L2110	O2	R2108	D8	R7561	F5
C2050	E5	C3002	J5	C7508	R4	L2202	J4	R2109	D8	R7562	F5
C2051	I5	C3003	K8	C7509	R4	L2205	J4	R2110	A7	R7563	F5
C2052	D4	C3004	K8	C7511	S4	L2301	L4	R2111	B7	R7564	F5
C2071	N4	C3005	J8	C7513	R4	L2302	L4	R2200	L2	S	
C2073	S2	C3006	I8	C7515	T4	L2304	K4	R2250	O2	S2403	V5
C2074	E8	C3007	J8	C7516	S4	L2305	L4	R2251	O2	S2404	F1
C2077	E8	C3008	K8	C7518	R5	L2310	K3	R2303	L4	T	
C2078	E8	C3009	I8	C7520	T8	L2402	T3	R2304	J5	T7501	S3
C2103	P1	C3010	N5	C7521	T8	L2404	U3	R2400	G4	T7520	T8
C2104	N2	C3013	K7	C7522	R7	L2405	N2	R2406	O2	U	
C2105	D8	C3014	K7	C7523	T8	L3200	D8	R2407	H5	U1	O1
C2201	J2	C3100	F2	C7524	R7	L3301	Q6	R2408	H4	U2	S1
C2202	L2	C3115	O7	C7525	R9	L3303	P8	R2418	I4	V	
C2203	K2	C3116	O7	C7560	S3	L3304	O8	R2419	I5	V2000	A3
C2211	J4	C3201	D8	C7562	R6	L3351	Q3	R2423	H4	V2402	H4
C2213	J2	C3202	E8	C7563	R5	L3352	Q3	R2424	I4	V2404	D8
C2215	J3	C3203	D8	C7564	T4	L6030	R2	R2425	G4	V2405	J3
C2216	J2	C3210	E8	C7565	R5	L6031	R2	R2426	I4	V2406	G2
C2217	L3	C3211	F9	C7566	R4	L6032	Q1	R2430	H4	V2407	G8
C2220	K3	C3300	Q6	D	L6077	R2	R2803	L8	V2408	D2	
C2222	J4	C3301	Q5	D2800	M7	L6100	E7	R2804	L8	V2409	J7
C2226	J4	C3302	Q4	D3000	J7	L6101	D6	R2830	N7	V2410	I4
C2227	J3	C3303	O8	D3300	P7	L7010	Q5	R3000	J5	V2411	I4
C2228	J3	C3304	O7	D3350	P3	L7011	Q4	R3002	L8	V2412	J6
C2229	J2	C3305	P6	E	L7500	S6	R3003	K6	X		
C2231	K4	C3306	O8	E2001	E4	L7501	S6	R3004	K7	X1001	U3
C2232	J3	C3307	P8	E2002	A6	L7502	R5	R3200	D7	X2000	B6
C2300	L3	C3308	Q5	E2003	E4	L7503	R8	R3201	E7	X2002	B2
C2301	L3	C3309	Q5	E2010	A6	L7504	S6	R3202	E8	X2030	B4
C2302	M3	C3310	Q6	E2101	Q6	L7505	S6	R3205	E8	X2060	A4
C2303	L2	C3313	P8	E2102	Q8	L7515	S4	R3206	E8	X2070	N3
C2304	M3	C3314	Q8	E2103	U6	L7561	R5	R3300	Q7	X2700	H3
C2306	J4	C3352	P3	E2104	U6	M		R3301	Q7	X3200	G7
C2307	L5	C3353	P3	E2105	U7	M2100	C8	R3305	O7	X3300	O5
C2309	M5	C3354	P3	E2106	U5	N		R3306	Q7	X7000	U8
C2312	L2	C3355	Q3	E2401	D9	N2030	E5	R3307	Q7	Z	
C2314	K4	C6020	U2	E2402	A4	N2031	D3	R3312	I8	Z2001	C2
C2315	L4	C6031	R1	E2403	L9	N2200	K3	R3313	I8	Z2400	H4
C2318	L3	C6032	Q2	E2404	L1	N2300	L2	R3314	P6	Z2401	V4
C2403	O1	C6033	Q2	E2405	D1	N2301	K4	R3351	Q6	Z2402	T1
C2404	U2	C6034	Q2	E2406	T1	N2401	H5	R3353	Q3	Z6030	R2
C2405	U4	C6035	Q1	E2407	T9	N3200	E7	R6005	O2	Z7001	U8
C2414	T2	C6036	Q2	E3350	P2	N3300	P8	R6020	T2	Z7002	U8
C2415	T4	C6037	Q2	E3351	P2	N3301	O6	R6030	Q2	Z7501	S7
C2416	U3	C6038	R1	E6001	U1	N6030	Q2	R6031	R1	Z7503	R6
C2417	U3	C6039	Q2	E6003	U1	N6101	E6	R6032	Q1	Z7504	S7
C2418	T3	C6040	Q2	E7000	V7	N6102	E6	R6034	R2	Z7520	T7
C2700	I2	C6051	R2	E7001	V5	N6103	E6	R6037	R1		
C2701	I2	C6052	R2	E7501	U9	N7505	S5	R6100	E7		
C2800	L8	C6055	R2	E7502	T9	N7520	S8	R6101	E5		
C2801	N8	C6101	D5	E7503	V8			R6103	E7		

